

# TYPHOON



Software GUI  
**UNYCO**

**VISIRAT<sup>2</sup>**  
INSIDE

# TYPHOON **HRS**



**STD** CAMERA SORTER  
WITH SUCTION EJECTION

**HRS** CAMERA SORTER WITH  
HIGH RESOLUTION SUCTION EJECTION



# TYPHOON

## TYPHOON HFS

**Typhoon** is an optical sorting machine with the highest resolution cameras to examine the product on the conveyor belt.

The system is dedicated to checking the food products in pulpy or liquid form such as fruit pulp, crushed or extruded tomatoes or pulpy diced fruit and tomatoes.

**Typhoon** can dispose of colour defects, marked produce and foreign bodies also the same colour as the good product.

The product is fed onto the inspection belt forming a light layer. The inspection zone is clearly separated from the ejection zone to avoid product sprays which can prejudice selection over time.

**Typhoon** is equipped with a reject system with vacuum extractor. Based on the size of the product particles, the reject system can be equipped with 64, 88, 128 or 176 extractor nozzles. The diameter of the extractor nozzles always vary based on the size of the particles of product from a minimum of 8 mm to a maximum of 23 mm. **Typhoon** can be equipped with a single ejector system or can have two reject systems to select fine and diced pulp.

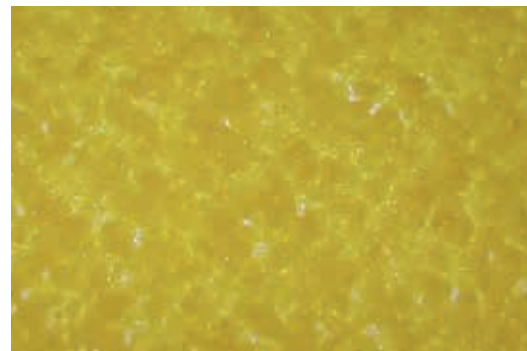
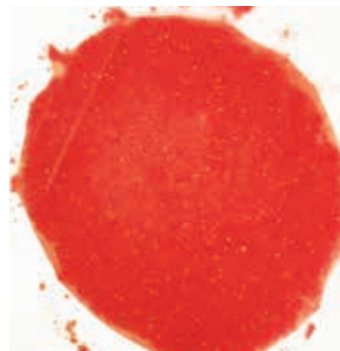
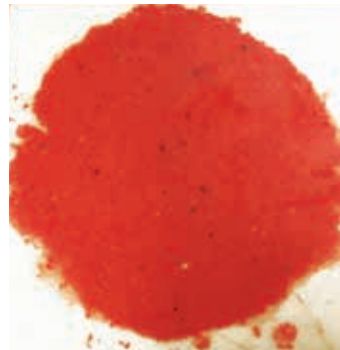



Customers benefit from the unique **Raytec Decaray** technology installed in both **Typhoon STD** and **Typhoon HRS** sorters.

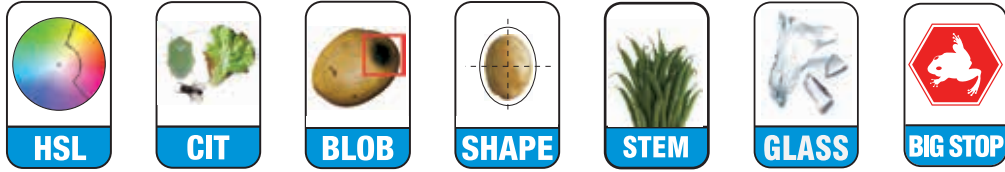

**The HSL Colour function**

HSL (Hue, Saturation, Lightness) is a color analysis function. Compared to RGB, HSL is a color representation similar to human perception.

**The Cit function**

Visible color analysis is often insufficient for the identification of foreign bodies. CIT (Chlorophyll, Infrared, Transparency) analysis highlights foreign bodies on the basis of: low fluorescent light emission, low infrared light reflection, transparency.

**The Blob function**

A "Blob" is a group of pixels next to each other that are recognized as incorrect by the sorting recipe. The BLOB function rejects only the groups of pixels (blobs) whose sum of weights is higher than a defined value.



**The Shape function**

The SHAPE function calculates nine mathematical parameters for each inspected object. Those parameters are representative of geometric characteristics of the object such as eccentricity, compactness, or the presence of protuberance.

**Stem function**

The STEM function allows the detection and rejection of any stalk or stem or wire that can be present in the product. STEM function analyzes if there are thin objects in the product stream.

**The Glass function**

This function allows the detection and rejection of any kind of transparent piece of glass and plastic. The GLASS function can be used with every kind of product as it does not influence the other sorting parameters.

**Function Big Stop**

This function allows controlling the presence of dangerous foreign bodies that we can find. The typical samples are the frog or the mouse. The "Big Stop" allows a series of programmable choice as: object calculation allocated in three different classes of dangerousness. Automatic image capture of dangerous contaminates, alarm generation (with option to stop the machine).

REJECTION SYSTEM **TYPHOON HRS**



REJECTION SYSTEM **TYPHOON**



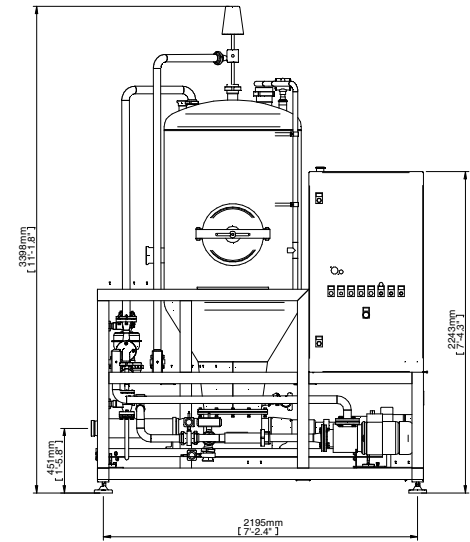
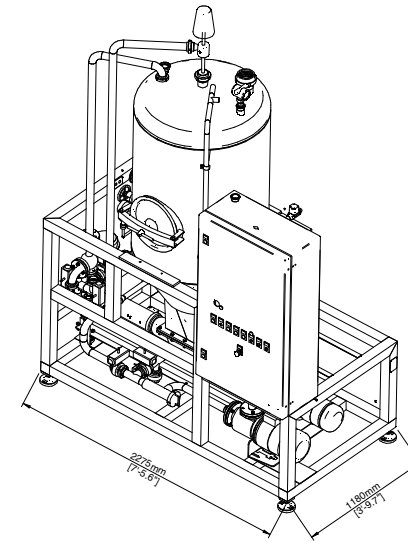
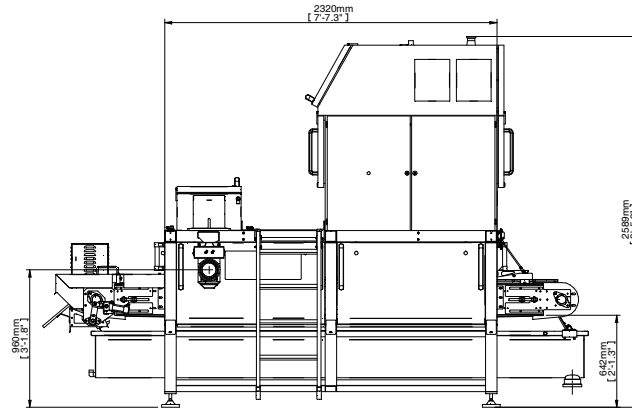
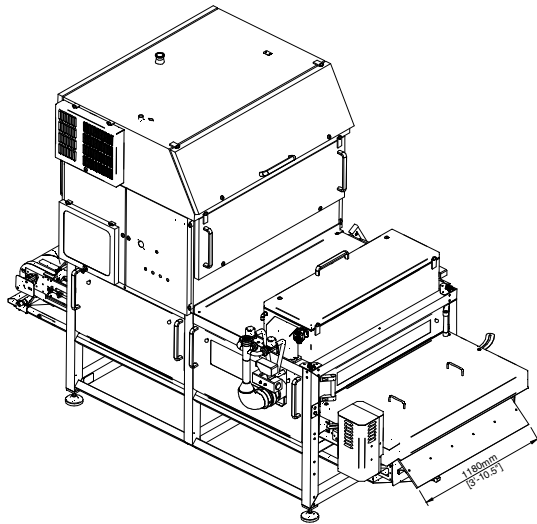

MODEL	T64-25	T64-18	T88	T128 HRS	T176 HRS	T64-176 3W
CAPACITY	Up to 18 t/h	Up to 15 t/h	Up to 10 t/h	Up to 5 t/h	Up to 5 t/h	Up to 5 t/h
LENGTH OF MACHINE	3520 mm	3520 mm	3520 mm	3520 mm	3520 mm	4715 mm
INSPECTION BELT WIDTH	1082 mm	1082 mm	1082 mm	1082 mm	1082 mm	1082 mm
INSPECTION BELT SPEED	90 m/min	90 m/min	90 m/min	90 m/min	90 m/min	90 m/min
PIXEL SIZE	0,5x0,5 mm	0,5x0,5 mm	0,5x0,5 mm	0,5x0,5 mm	0,5x0,5 mm	0,5x0,5 mm
NUMBER OF EXTRACTOR NOZZLES	25	64	88	128	176	64+176
DIAMETER OF EXTRACTOR NOZZLES	23 mm	18 mm	14 mm	12 mm	8 mm	25 + 8 mm