

RAYBOX



X-RAY FULL CONTAINER INSPECTION MACHINE

to control products in glass jars, glass bottles, tinplate cans, carton bricks, plastic containers.



X-ray is a valid method for tracing and rejecting various types of (high density) contaminants. The minimum size is strongly affected by the type of container, its shape and the type of product it contains:

- Glass fragments with sizes from 3x3x3 mm (glass in glass)
- Metal fragments (iron, steel, copper, etc.), with sizes from 1x1x1 mm
- Stones and bones with sizes from 3x3x3 mm
- Some plastics and rubbers depending on the composition and relative density.

The effectiveness of the control, as well as the minimum detectable defect, is proportionate to the minimum number of false rejects, which in Raytec systems is considered to be 3/1000 inspected products.

In addition to detecting foreign bodies, it is also possible to control:

- The shape and conformity of the container (such as dents or breakages)
- Filling level
- Easy Open side in tinplate cans.

RAYBOX Can

Raybox main characteristics:

- Standard View;
- High flexibility in product changeover to inspect different kind of containers;
- Possibility to inspect small and big cans (up to 5 kg);
- Low X-Ray emission 0,1 μ sv;
- Compact design to be installed in tight spaces;
- High capacity (up to 2000 cpm).

RAYBOX Panoramic

Raybox main characteristics:

- Panoramic View and Standard View;
- High flexibility in product changeover to inspect different kind of containers;
- Possibility to inspect tinplate cans and glass jars;
- Low X-Ray emission 0,1 μ sv;
- Compact design to be installed in tight spaces;
- High capacity (up to 2000 cpm).



Automatic check of the protective screens and beam-traps position. If those devices are in the wrong position the machine does not run.



VIEWING TECHNIQUE

The years of development and accumulated experience in the field of Panoramic vision are confirmed by RAYBOX, which offers increased performance thanks to the new algorithms implemented in the system. Contrary to other systems present on the market, the ray-emission lamp is automatically oriented by the software to obtain a better image of the jar and its base.

MONOBLOCK GENERATOR

One of the main intentions of the RAYBOX project was to eliminate some of the weak points in generating X-rays. While maintaining its ability to be fitted with all generators and lamps available on the market, this new inspection machine uses a monoblock generator-lamp unit (with no high-voltage cable) that increases reliability and reduces maintenance costs.

REJECTS

RAYBOX can be fitted with a single or multiple expulsion system positioned outside the machine, both of which are controlled by an automatism that assures not only the synchronisation of the expulsion of the rejected jar, but also monitors its effective expulsion. The reject system is positioned outside the machine to facilitate reject condition monitoring.

3 WAY REJECTION

Thanks to the presence of two distinct reject systems, RAYBOX allows to differentiate contaminated tins from tins whose easy open lid is upside down (available for 1/2 kg cans). Those tins are conveyed to a twisting unit and return in line.



STANDARD VIEW:

The X-ray source is aligned with the conveyor belt. The bottom of the containers appears as a dark line.

PANORAMIC VIEW:

The X-ray source is aligned with the top of the containers and their bottom appears as an ellipse. If the container height changes the machine automatically adapts the X-ray source position.

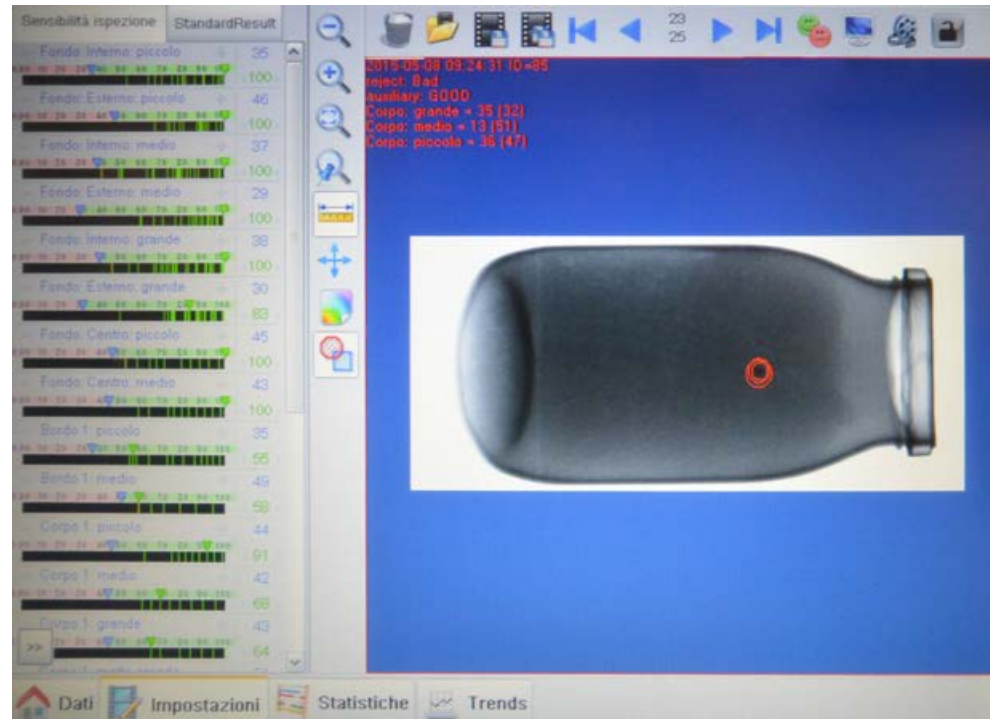

STANDARD VIEW

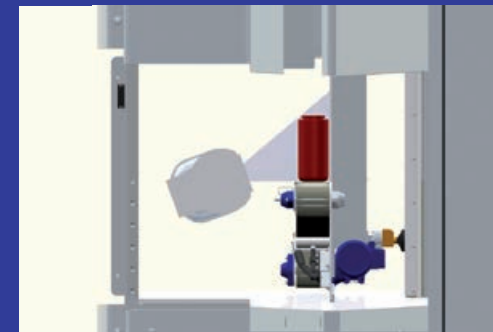

PANORAMIC VIEW

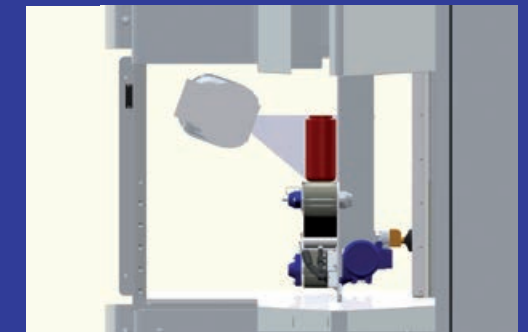

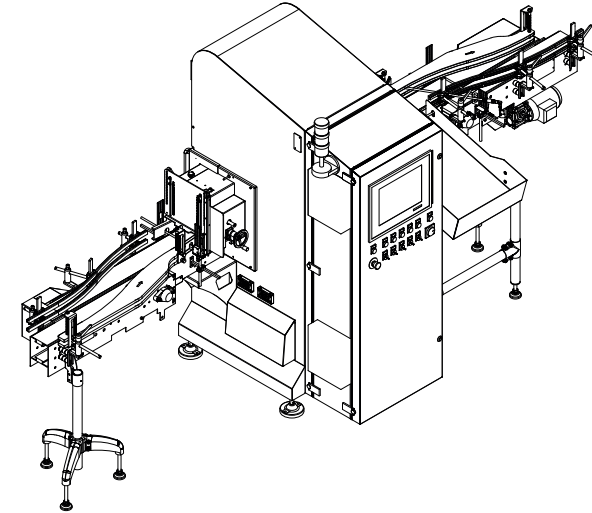
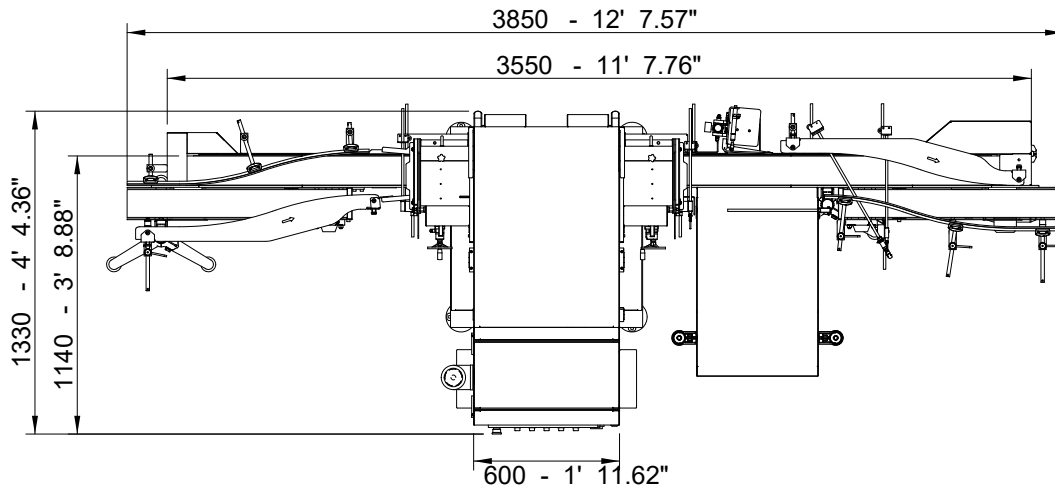
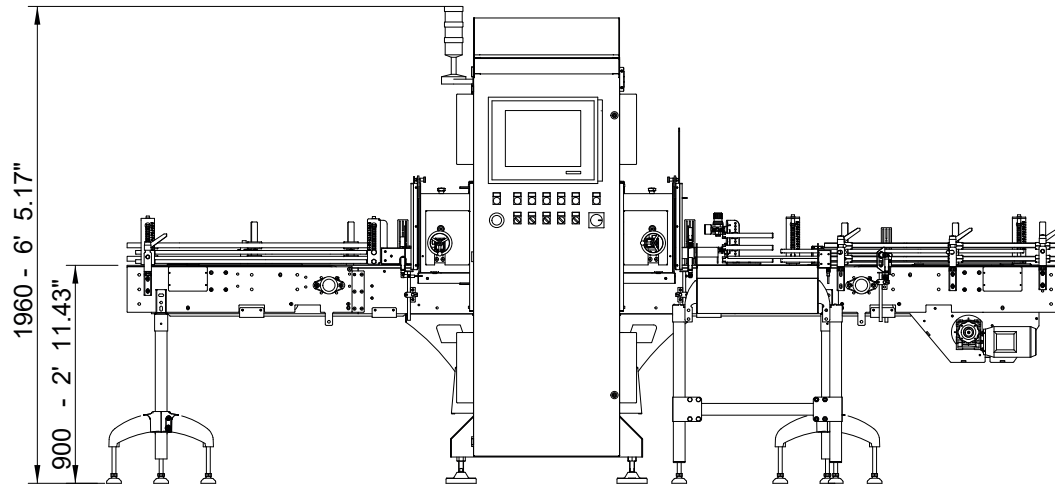

TECHNICAL FEATURES

Typical inspectable containers	Glass Jars, Tinplate Cans, Carton Bricks, Plastic Jars
Max diameter	155 mm [6"]
Max inspection speed	100 m/min (Standard 45 m/min) [328 ft/min (Standard 147 ft/min)]
Sensor height	307 mm [12"]
Pixel size	0,4x0,4 mm – 0,8x0,8 mm [0.015"x0.015" – 0.031"x0.031"]
Ejection type	Electro pneumatic Cylinder
Operator interface	17" color touch-screen monitor
External and/or remote access	Ethernet or modem
Frame material	AISI 304
Sensor protection degree	IP55
Power supply and consumption	
Machine power supply	3PH + GND
Machine voltage	400 V
Frequency	50 HZ
Power absorption (2motors)	3 kW
Processing unit power absorption	500 W
High Voltage generator	300 W – 1kW
Electrical switchboard protection degree	IP55
Compressed Air	
Operating pressure	4÷6 bar [58÷87 psi]
Max air consumption	50 NI/min [1.76 Ncuft/min] (**)

Note: (*) max pression 18bar - (**) depending on rejected product - (***) with generator of 1kW
All characteristics listed above are not binding and are subjected to change without previous notice.