



# DRYCE

DR-602 | DR-1202



PULSED LED LIGHT



## TECHNOLOGIES

## ADVANTAGES

## DETAILS



PULSED LED LIGHT

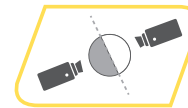

DOUBLE SIDE VIEW



4 x 4K

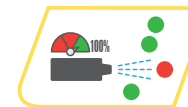

SMART JET



3WAY REJECT SYSTEM



ULTRA CLEAN



WATER PROTECTION

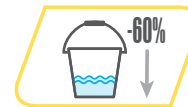

60% CLEANING WATER CONSUMPTION

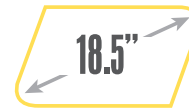

18.5"

DISPLAY VIEW



SAFETY ENGINEERING



NEW MACHINE AND TECHNOLOGY FOR DRIED AND FROZEN PRODUCTS

WWW.RAYTECVISION.COM



Innovation in Sorting Equipment

# DRYCE

DR-602

# DRYCE

DR-1202

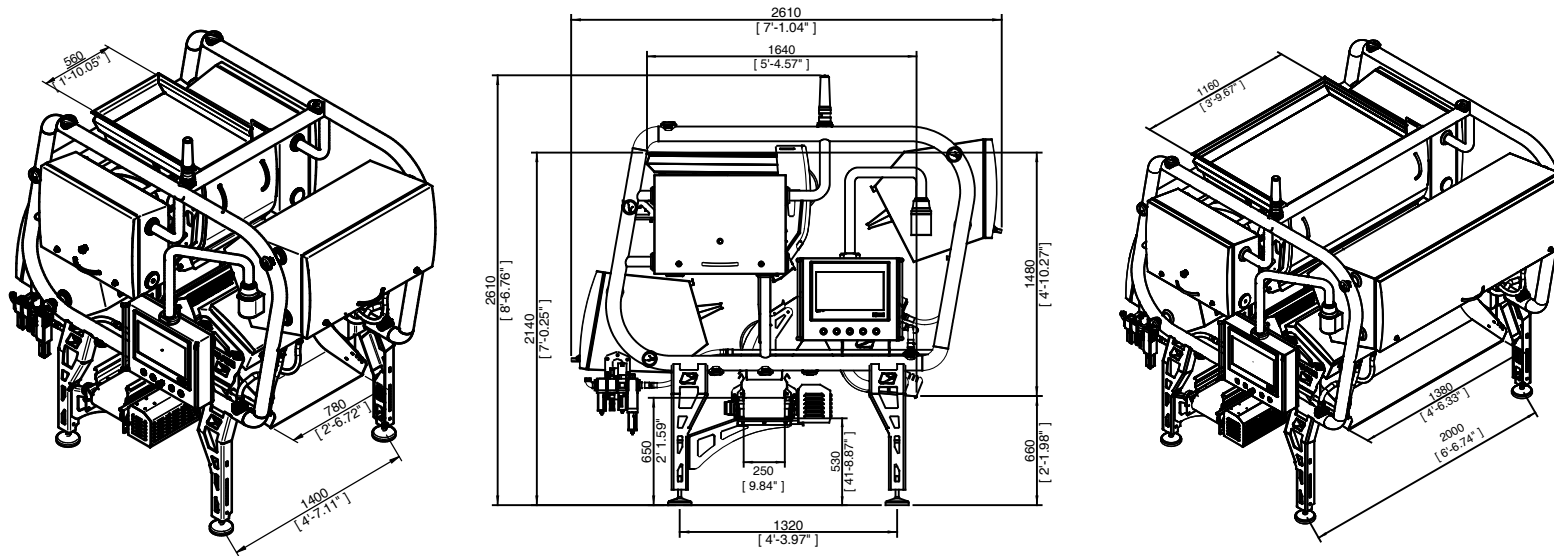

## TECHNICAL FEATURES

Optical Resolution	0,5x0,5mm [0.02"x0.02"]
Air Nozzles	96
Nozzle pitch	6mm [0.24"]
User Interface	18" LCD touch-screen monitor
Remote Connection	Ethernet

## UTILITIES

\* according to reject rate

Power Supply	3F+T [3PH+GND]
Voltage	400/480 V
Frequency	50/60 Hz
Installed Power	4 kW
Air Pressure	6-8bar [87-116psi]
Air Consumption (Typical)*	300NI/min [10Ncuft/min]
Air Consumption (Maximum)	1200NI/min [42Ncuft/min]
Weight	950 Kg

Dimensions, Specifications and Utilities are subject to change without notice

## TECHNICAL FEATURES

Optical Resolution	0,5x0,5mm [0.02"x0.02"]
Air Nozzles	192
Nozzle pitch	6mm [0.24"]
User Interface	18" LCD touch-screen monitor
Remote Connection	Ethernet

## UTILITIES

\*\* according to reject rate

Power Supply	3F+T [3PH+GND]
Voltage	400/480 V
Frequency	50/60 Hz
Installed Power	4 kW
Air Pressure	6-8bar [87-116psi]
Air Consumption (Typical)*	450NI/min [15Ncuft/min]
Air Consumption (Maximum)	1200NI/min [42Ncuft/min]
Weight	1400 Kg

Dimensions, Specifications and Utilities are subject to change without notice